

1 Watt

- Single Unregulated Output
- $\pm 10\%$ Input Range
- SMD DIP8 Package
- 1.5kVDC Isolation, 3kVDC Option
- Industry Standard Pinout
- UL62368-1 Safety Approvals
- Continuous Short Circuit Protection
- Tape & Reel Package Available
- Operating Temperature -40°C to +105°C
- Full Load to 100°C
- 3 Year Warranty



Dimensions:

IES01:
0.52 x 0.335 x 0.285" (13.2 x 8.5 x 7.25 mm)

The single output IES01 series is an ideal solution for isolating voltage rails in a distributed power supply architecture such as analog, digital, data and relay circuits. This product family offers a compact design with high efficiency, 1.5kV isolation with 3.0kV optional, short circuit protection and high operating temperature.

Models & Ratings

Input Voltage	Output Voltage	Output Current		Input Current ⁽¹⁾		Maximum Capacitive Load	Efficiency ⁽²⁾	Model Number ^(3,5)
		Minimum	Maximum	No Load	Full Load			
5V (4.5-5.5 V)	3.3V	30mA	303mA	5mA	270mA	2400µF	74%	IES0105S03
	5V	20mA	200mA	5mA	270mA	2400µF	82%	IES0105S05
	6V	17mA	167mA	5mA	270mA	2400µF	82%	IES0105S06 ⁽⁶⁾
	9V	12mA	111mA	12mA	241mA	1000µF	83%	IES0105S09
	12V	9mA	84mA	12mA	241mA	560µF	83%	IES0105S12
	15V	7mA	67mA	18mA	241mA	560µF	83%	IES0105S15
	24V	4mA	42mA	18mA	241mA	220µF	85%	IES0105S24

Notes

1. Typical input currents measured at nominal input voltage.
2. Typical value at full load.
3. Optional 3kVDC isolation add suffix '-H'.
4. Standard tube quantity = 38.
5. For tape & reel option add suffix '-TR'. Reel quantity = 500.
6. The 6V model is currently available with 1.5kV isolation only and without UL safety certification.

Mechanical Details

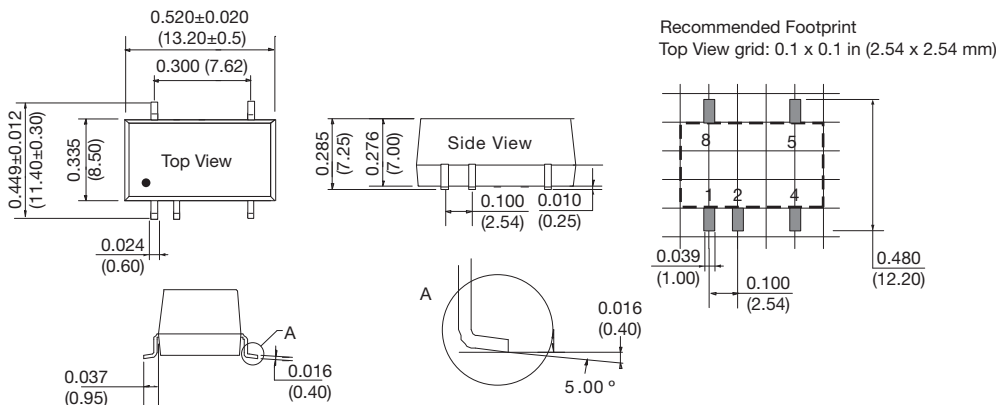

PIN CONNECTIONS	
Pin	Function
1	-Vin
2	+Vin
4	-Vout
5	+Vout
8	No Connection ⁽⁵⁾

Notes

1. All dimensions are in inches (mm).
2. Weight: 0.003lbs (1.4g) typical.
3. Pin pitch and length tolerance: ± 0.004 (± 0.10).
4. Case tolerance: ± 0.02 (± 0.5).
5. Pin 8 leave floating.

Input

Characteristic	Minimum	Typical	Maximum	Units	Notes & Conditions
Input Voltage Range	4.50		5.50	VDC	5 V nominal
Input Current					See Models and Ratings table
Input Reflected Ripple		15		mA pk-pk	Through 4.7µH inductor and 220µF capacitor
Input Surge			9	VDC for 1 s	5 V models
Input Filter	Capacitor				

Output

Characteristic	Minimum	Typical	Maximum	Units	Notes & Conditions
Output Voltage	3.3		24	VDC	See Models and Ratings table
Initial Set Accuracy				%	See Load Regulation Curves
Minimum Load	10			%	
Line Regulation			±1.2	%	Per 1% change of input voltage (±1.5% for 3V3 output)
Load Regulation				%	See load regulation curves
Ripple and Noise		30/50	75/100	mV pk-pk	For models ≤15 V/24 V models, 20 MHz bandwidth, measured using 0.1 µF capacitor
Short Circuit Protection					Continuous, with auto recovery
Maximum Capacitive Load				µF	See Models and Ratings table
Temperature Coefficient			±0.02	%/°C	

General

Characteristic	Minimum	Typical	Maximum	Units	Notes & Conditions
Efficiency					See Models and Ratings table
Isolation: Input to Output	1500/3000			VDC	IES/IES-H
Switching Frequency	270		278	kHz	Low input voltage 10% load to high input voltage at full load
Isolation Resistance	10 ⁹			Ω	Input to output, tested at 500 VDC
Isolation Capacitance		20		pF	Input to output
Power Density			20.8	Win ³	
Mean Time Between Failure	3500			kHrs	MIL-HDBK-217F, +25 °C GB
Weight		0.003 (1.4)		lb (g)	
Moisture Sensitivity Level (MSL)	Level 1				
Case Material	Black plastic, flame retardant UL94 V-0				
Pin Material	Phosphor bronze, solder coated				
Recommended Solder Profile	IPC/JEDEC J-STD-020D.1				Peak temp ≤245 °C, max duration, ≤60s at 217 °C
Water Wash	Non-soaking water wash with de-ionised water. Dry thoroughly.				

Environmental

Characteristic	Minimum	Typical	Maximum	Units	Notes & Conditions
Operating Temperature	-40		+105	°C	Derate from 100% load at +100 °C to 80% load at 105 °C
Storage Temperature	-55		+125	°C	
Case Temperature			+105	°C	
Case Temperature Rise		25/15		°C	Ambient 25°C, 3V3 output/others
Operating Humidity			95	% RH	Non-condensing
Cooling					Natural convection

Safety Approvals

Safety Agency	Safety Standard	Notes & Conditions
UL	UL62368-1	

EMC: Emissions

Phenomenon	Standard	Test Level	Notes & Conditions
Conducted	EN55032	Class B	See Application Note for Class B filter
Radiated	EN55032	Class B	See Application Note for Class B filter

EMC: Immunity

Phenomenon	Standard	Test Level	Criteria	Notes & Conditions
ESD Immunity	EN61000-4-2	Air $\pm 8\text{kV}$, Contact $\pm 4\text{kV}$	B	

Load Regulation

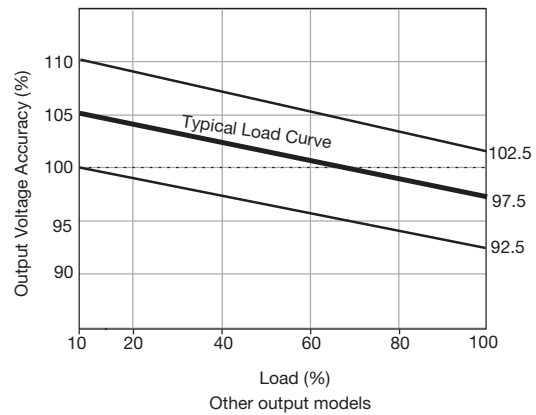
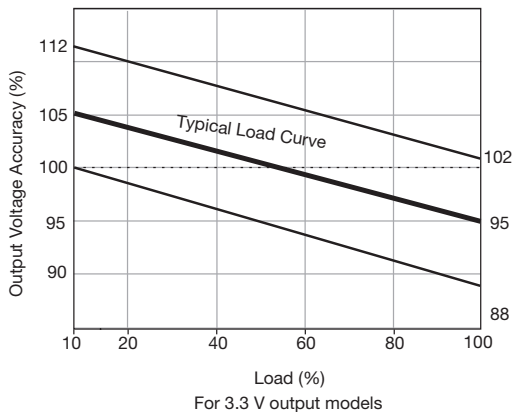

Application Note

EMI Filter for Class B Emissions

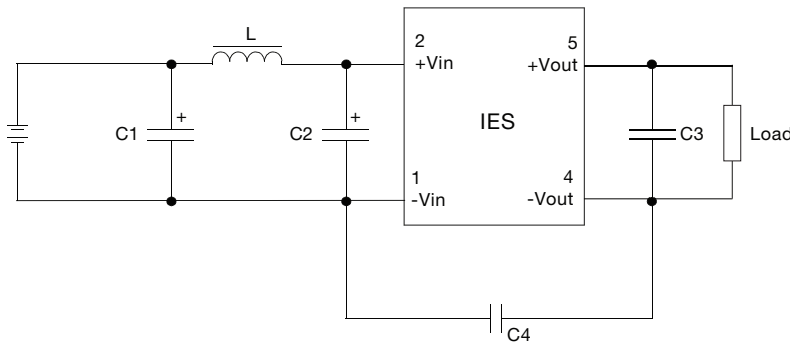

Component	Output Voltage						Notes
	3.3V	5V	9V	12V	15V	24V	
C1, C2	4.7 μF	4.7 μF	4.7 μF	4.7 μF	4.7 μF	4.7 μF	25V rated
C3	10 μF	10 μF	4.7 μF	2.2 μF	1 μF	0.47 μF	25V rated
C4	Not fitted			1nF	1nF	1nF	2kV rated, ML Ceramic
L	6.8 μH	6.8 μH	6.8 μH	6.8 μH	6.8 μH	6.8 μH	

Application Note

Temperature Derating Curve

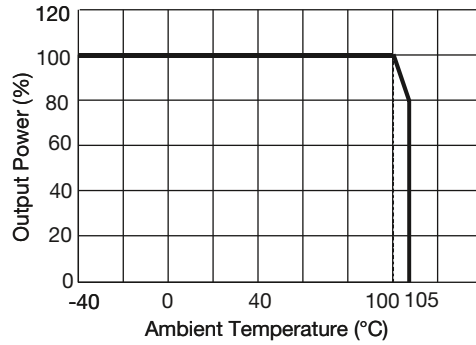

Efficiency vs Input Voltage (example IES0105S05)

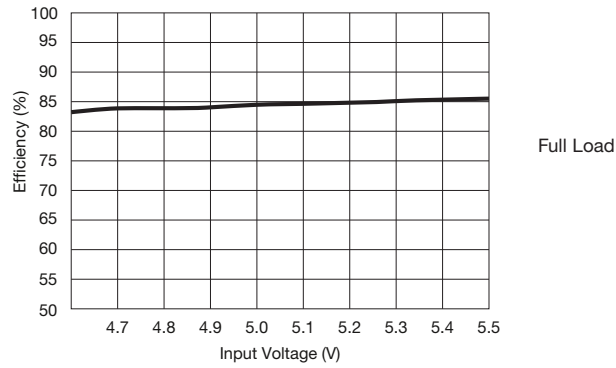

Efficiency vs Output Load (example IES0105S05)

